

SHIELD - SHIELD A4

INSTALLATION MANUAL



INCLUDED IN THE PACKAGE



AS/NZS 5532:2013
AS/NZS 1891.2:2001
Fe: min 0,42 mm



EN 795 TYPE A
Fe: min 0,4 mm
Al: min 0,6 mm



EN 795 TYPE C
Fe: min 0,5 mm
Al: min 1 mm

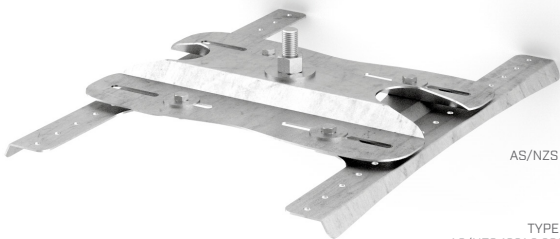

AS/NZS 5532:2013



TYPE A
TYPE C + SPEAR
AS/NZS 1891.2:2001 + SPEAR



TYPE C + SPEAREVO



read also:



SHIELD-SHIELD A4
Installation
Manual



SHIELD-SHIELD A4
Safety
Regulations



EN
795:2012
A+C

CEN/TS
16415:2013

UNI
11578:2015
A+C

AS/NZS
1891.2:2001

AS/NZS
5532:2013



SHIELD-SHIELDA4
Installation
Manual

+



SHIELD-SHIELDA4
Safety
Regulations

TOOLS



AS/NZS 5532:2013
AS/NZS 1891.2:2001

SAFETY INSTRUCTIONS

- IT** L'installazione e/o utilizzo del prodotto Rotho Blaas è permessa solo a personale esperto previa lettura e comprensione del **1** **MANUALE D'INSTALLAZIONE** e delle **2** **NORME DI SICUREZZA** nella lingua del relativo Paese di utilizzo.
- DE** Die Installation und/oder die Verwendung des Produkts von Rotho Blaas ist ausschließlich Fachpersonal vorbehalten, nachdem es das **1** **INSTALLATIONSHANDBUCH** und die **2** **SICHERHEITSVORSCHRIFTEN** in der Sprache des Verwendungslandes gelesen und verstanden hat.
- EN** Only qualified personnel may install and/or use this Rotho Blaas product, after reading and understanding the **1** **INSTALLATION MANUAL** and the **2** **SAFETY REGULATIONS**, in the language of the country of use.
- ES** La instalación y/o el uso del producto Rotho Blaas solo están permitidos al personal experto después de haber leído y comprendido el **1** **MANUAL DE INSTALACIÓN** y las **2** **NORMAS DE SEGURIDAD** en el idioma del país en el que se utiliza.
- FR** Seul le personnel expérimenté peut installer et/ou utiliser ce produit Rotho Blaas, après avoir lu et compris le **1** **MANUEL D'INSTALLATION** et les **2** **NORMES DE SECURITE** dans la langue du pays où le produit est utilisé.
- PT** A instalação e/ou utilização do produto Rotho Blaas só é permitida a pessoal especializado após a leitura e compreensão do **1** **MANUAL DE INSTALAÇÃO** e das **2** **NORMAS DE SEGURANÇA** na língua do respetivo país onde será utilizado.
- RU** К установке и (или) использованию продукции Rotho Blaas допускается только высококвалифицированный персонал после обязательного прочтения и усвоения **1** **РУКОВОДСТВО ПО УСТАНОВКЕ** и **2** **ПРАВИЛ ТЕХНИКИ БЕЗОПАСНОСТИ** на языке соответствующей страны использования.
- CS** Instalace a/nebo použití výrobku Rotho Blaas je povoleno pouze odborným osobám po přečtení a pochopení **1** **NAVODU K INSTALACI** a **2** **BEZPEČNOSTNÍCH PŘEDPISŮ** v jazyce příslušné země použití.
- DA** Kun kvalificeret personale må installere og/eller bruge dette Rotho Blaas-produkt efter at have læst og forstået den **1** **INSTALLATIONSMANUALEN** og **2** **SIKKERHEDSFORSKRIFTERNE** på brugerens sprog.
- EL** Η εγκατάσταση ή και η χρήση του προϊόντος Rotho Blaas επιτρέπεται μόνο σε έμπειρο προσωπικό που έχει διαβάσει και κατανοήσει τις **1** **ΕΓΧΕΙΡΙΔΙΟ ΕΓΚΑΤΑΣΤΑΣΗΣ** και τους **2** **ΚΑΝΟΝΙΣΜΟΥΣ ΑΣΦΑΛΕΙΑΣ** στη γλώσσα της σχετικής χώρας χρήσης.
- ET** Antud Rotho Blaasi toodet tohib paigaldada ja / või kasutada ainult kvalifitseeritud personal, kes on lugenud kasutamise riigi keeles **1** **PAIGALDUSJUHENDIS** ja **2** **OHUTUSEESKIRJU** ning nendest aru saanud.
- FI** Tämän Rotho Blaas -tuotteen asennus ja/tai käyttö on sallittu vain asiantuntevan henkilöstön toimesta sen jälkeen, kun he ovat lukeneet ja ymmärtäneet **1** **ASENNUSOHJEIDEN** ja **2** **TURVALLISUUSMÄÄRÄYKSET** käyttömaan kielellä.
- HR** Postavljanje i/ili uporaba proizvoda Rotho Blaas dopuštena je samo stručnom osoblju koje je prethodno pročitalo i razumjelo **1** **UPUTA ZA MONTAŽU** kao i **2** **PROPISE O SIGURNOSTI** na jeziku zemlje uporabe.
- HU** A Rotho Blaas terméket kizárólag hozzáértő személyzet szerelheti be és/vagy használhatja, az adott országnak megfelelő nyelvű **1** **TELEPÍTÉSI KÉZIKÖNYV** és **2** **BIZTONSÁGI SZABÁLYOK** elolvasása és megértése után.

INFORMATION

Type
Rothoblaas
SHIELD

Related standard(s)
EN 795:2012 A+C
CEN/TS 16415:2013
UNI 11578:2015 A+C
AS/NZS 5532:2013
AS/NZS 1891.2:2001

Maximum number of users
4/2/1 user(s)

Name or logo of manufacturer/
distributor
ROTHOBLAAS

Serial number and year of
manufacture

XXXXYY

(XXXX = lot number - YY = year)



SHIELD-SHIELD4
Installation
Manual



SHIELD-SHIELD4
Safety
Regulations

PRODUCT INFORMATION



AS/NZS 5532:2013



TYPE A
TYPE C + SPEAR
AS/NZS 1891.2:2001
+ SPEAR



TYPE C + SPEAREVO



EN
795:2012
A+C

CEN/TS
16415:2013

UNI
11578:2015
A+C



AS/NZS
1891.2:2001

AS/NZS
5532:2013

SAFETY INSTRUCTIONS

- IS** Aðeins þjálfað starfsfólk má setja upp og/eða nota þessa Rotho Blaas-vöru eftir að hafa lesið og skilið **1** UPPSETNINGARHANDBÓKAR og **2** REGLUGERDIR UM ÖRYGGI á tungumáli þess lands sem varan er notuð í.
- LT** Produkta „Rotho Blaas“ montuoti ir (arba) naudoti leidžiama tik patyrusiam personalui, prieš tai perskaičius ir supratęs **1** MONTAVIMO VADOVE ir **2** SAUGOS TAISYKLES atitinkamos šalies, kurioje eksploatuojama, kalba.
- LV** Rotho Blaas produkta uzstādīšana un/vai lietošana ir atļauta tikai pieredzējušam darbiniekam pēc **1** UZSTĀDĪŠANAS ROKASGRĀMATĀ un **2** DROŠĪBAS NĒTIKUMU izlasīšanas un izpratnes attiecīgās valsts valodā, kurā produkts tiks lietots.
- NL** De installatie en/of het gebruik van het product Rotho Blaas is voorbehouden aan uitsluitend vakbekwaam personeel dat de **1** INSTALLATIEHANDLEIDING en de **2** VEILIGHEIDSVOORSCHRIFTEN in de taal van het land van gebruik gelezen en begrepen heeft.
- NO** Dette Rotho Blaas-produktet skal bare installeres og/eller brukes av kvalifisert personell som har lest og forstått **1** INSTALLASJONSHÅNDBOKEN og **2** SIKKERHETSFORSKRIFTENE, på det språket som brukes i landet produktet anvendes.
- PL** Instalacji i/lub użytkowania produktu Rotho Blaas może dokonać wyłącznie doświadczony personel, który przeczytał i zrozumiał **1** INSTRUKCJI INSTALACJI oraz nowy **2** BEZPIECZENSTWA w języku kraju użytkowania.
- RO** Instalarea și/sau utilizarea produsului Rotho Blaas este permisă numai personalului expert, după ce a citit și înțeles **1** MANUALUL DE INSTALARE și **2** NORMELE DE SIGURANȚĂ în limba țării de utilizare a produsului.
- SK** Inštalácia a/alebo používanie produktu Rotho Blaas je povolené len skúsenému personálu po predchádzajúcom prečítaní a pochopení **1** NÁVODE NA INŠTALÁCIU a **2** BEZPEČNOSTNÝCH NORIEM v jazyku príslušnej krajiny používania.
- SL** Ta proizvod Rotho Blaas lahko namesti in/ali uporablja samo izkušeno osebeje, ki je prebralo in razume vse **1** NAVODILIH ZA VGRADNJO in **2** VARNOSTNE PREDPISE v jeziku države njegove uporabe.
- SV** Endast erfaren personal får installera och/eller använda den här Rotho Blaas-produkten efter att **1** INSTALLATIONSANVISNINGARNA och **2** SÄKERHETSFORESKRIFTER har lästs igenom på språket i installationslandet.
- TR** Sadece yetkili personel **1** KURULUM KILAVUZUNDA ve **2** GÜVENLİK MEVZUATINI (**2**) ürünün kullanıldığı ülke dilinde okuyup anladıktan sonra Rotho Blaas ürünü kurabilir ve/veya kullanabilir.
- JA** Rotho Blaas製品の施工および使用は、資格を有する専門家のみに許可されています。施工および使用の前に、必ず使用する国の言語で**1**設置マニュアルと**2**安全規則をお読み下さい。
- ZH** 只有具备合格资质的人员在阅读并理解以使用国的语言编写的**1**安装手册和**2**安全规程后才能安装和/或使用该Rotho Blaas产品。
- AR** يمكن فقط للفنيين المؤهلين باستخدام أو تركيب منتج Rotho Blaas بعد قراءة وفهم دليل التثبيت **1** نظراً لسلامة **2** بلغة البلد المستخدم فيها المنتج



AS/NZS 5532:2013
AS/NZS 1891.2:2001
FOR PERSONNEL
ATTACHMENT ONLY

15 kN
EN 10177
III

rothoblaas SHIELD

EN 795:2012 A+C

XXXXXX

CEN/TS 16415:2013

UNI 11578:2015 A+C

Type A, Type C + SPEAR

Type C + SPEAREVO



■ SHIELD DIMENSIONS

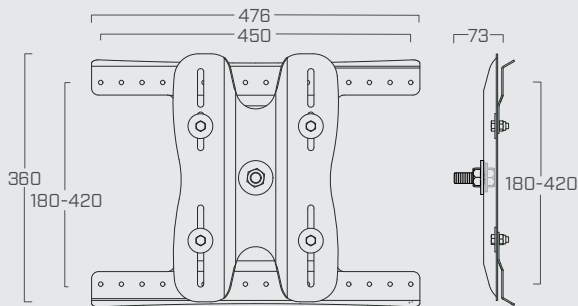

■ LOAD TEST MODEL

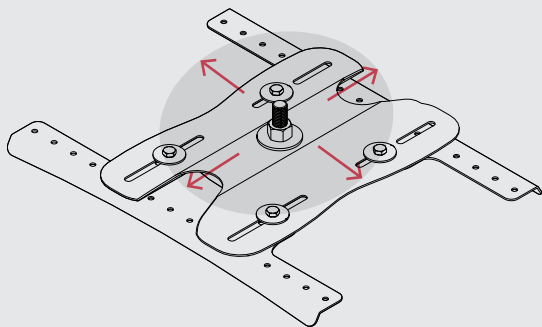

- IT ⚠ Verificare idoneità statica del sottofondo di montaggio!
- DE ⚠ Die statische Eignung des Montageuntergrundes sicherstellen!
- EN ⚠ Check the static suitability of the installation substrate!
- ES ⚠ ¡Compruebe la idoneidad estática del sustrato de montaje!
- FR ⚠ Vérifier l'adéquation statique du substrat d'assemblage!

SHIELD APPLICATION INSTRUCTIONS



EN
785:2012
A+C

CEN/TS
16415:2013

UNI
11578:2015
A+C

~~ABS/ES
18612:2001~~

~~ABS/ES
5532:2013~~

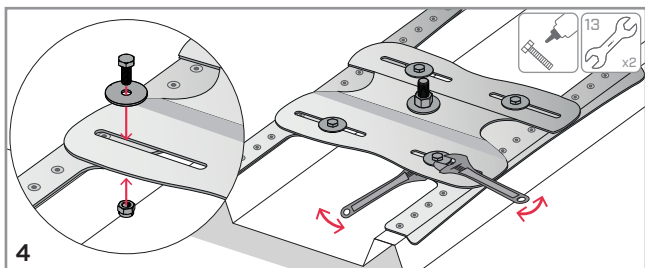
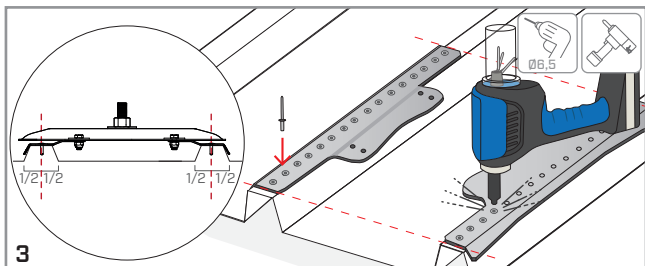
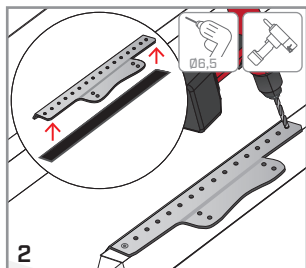
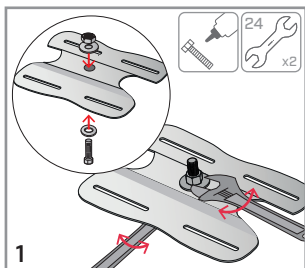

SHIELD APPLICATION INSTRUCTIONS



AS/NZS
1891.2:2001

AS/NZS
5532:2013

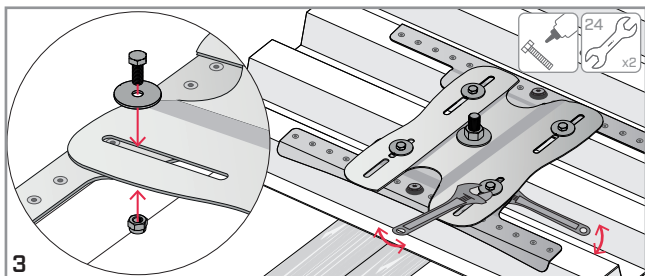
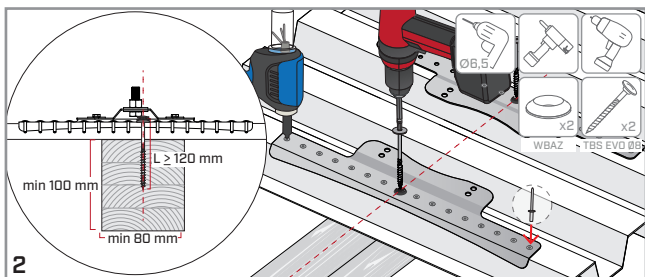
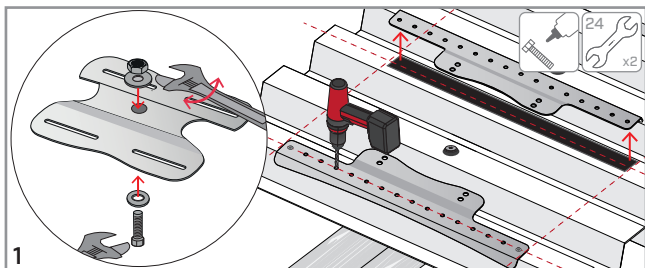

SHIELD APPLICATION INSTRUCTIONS



AS/NZS
1891.2:2001

AS/NZS
5532:2013

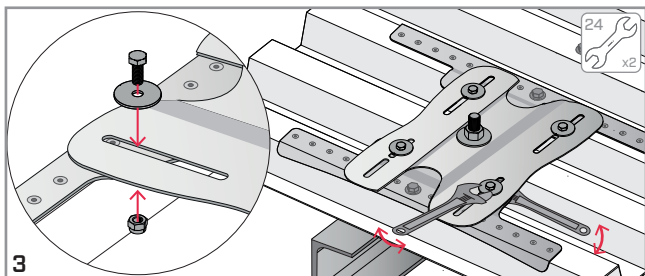
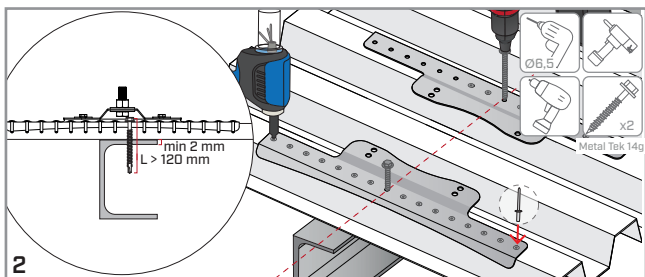
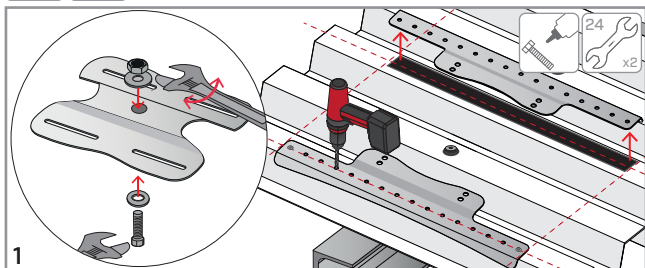

ANCHOR POINT

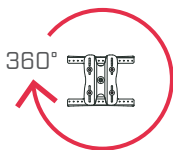

SHIELD + AOS01



AOS01
Installation
Manual

AOS01
Safety
Regulations

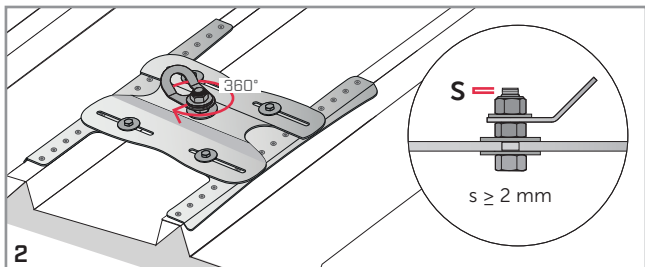
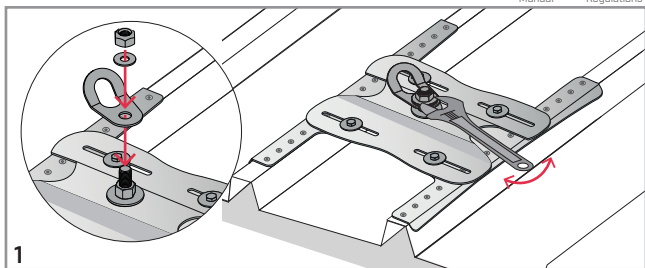

■ ANCHOR POINT

AS/NZS
1891.2:2001

AS/NZS
5532:2013

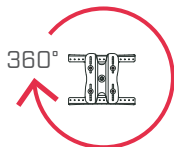

■ SHIELD + AOS01



AOS01
Installation
Manual

AOS01
Safety
Regulations

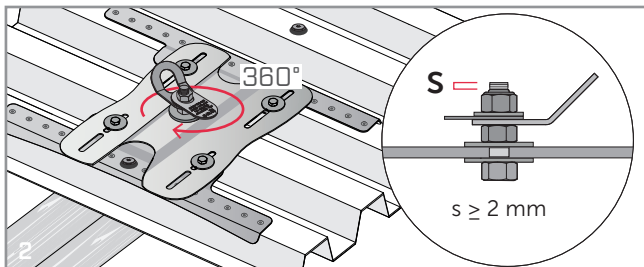
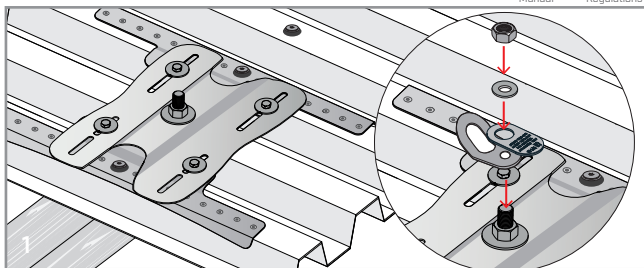

ANCHOR LINE

EN 795:2012 C	CEN/TS 18415:2013	UNI 11576:2015 C	AS/NZS 1891.2:2001	AS/NZS 5532:2013
---------------------	----------------------	------------------------	-----------------------	---------------------



SHIELD + PATROL + SPEAR

X = min 2 m X = max 7,5 m



PATROL + SPEAR
Installation
Manual



PATROL + SPEAR
Safety
Regulations

SHIELD + PATROL + SPEAREVO

X = min 2 m X = max 15 m



PATROL + SPEAREVO
Installation
Manual



PATROL + SPEAREVO
Safety
Regulations

SHIELD + PATROL

PATROLINT

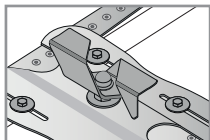

PATROLMED

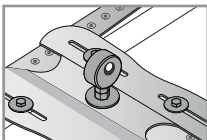

PASINT

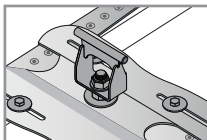

PASANG

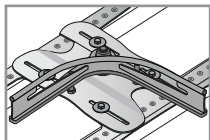

PATROLANG

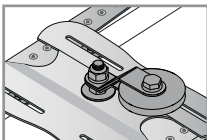

PASANGBEND + ANGSUP

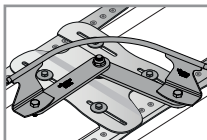

PATROLTERM

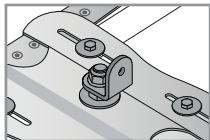

PATROLTERML

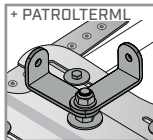
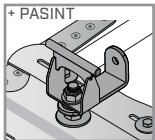

Solution for Safety

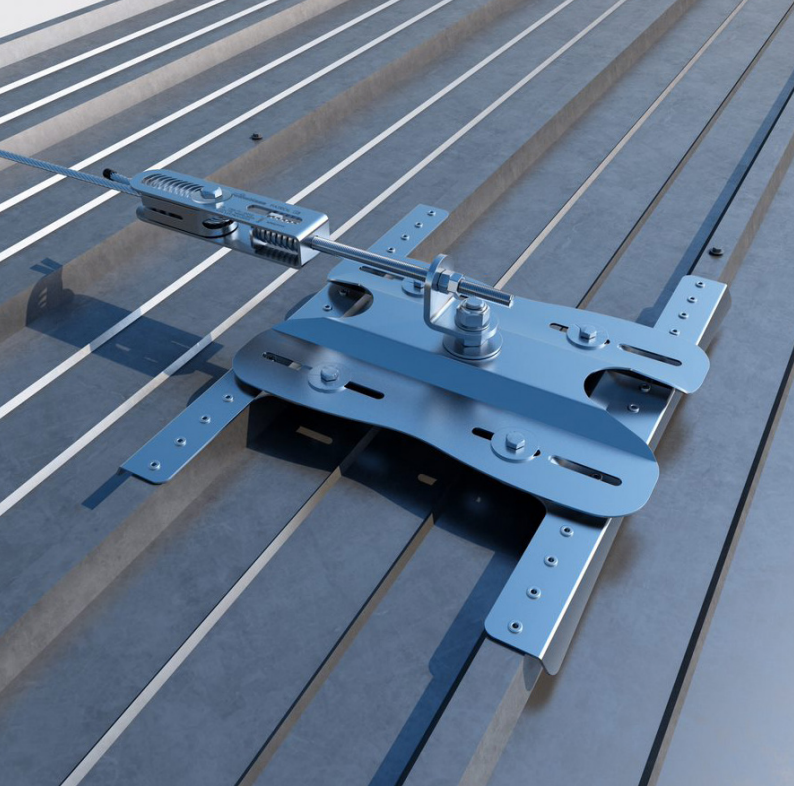

Rotho Blaas Srl

05-24

Via dell'Adige N.2/1 | 39040, Cortaccia (BZ) | Italia
Tel: +39 0471 81 84 00 | Fax: +39 0471 81 84 84
info@rothoblaas.com | www.rothoblaas.com

